

# Full-Fit RO Elements

Reverse Osmosis Elements for Food & Beverage Water Applications



## Key Features

- Deliver highflux and outstanding quality water for applications requiring sanitary-grade permeate.
- Full-fit configuration design that helps minimize stagnant areas for sanitary designs.

## Key Applications

- Food & Beveragewater applications
- Sanitary uses when permeate is the final product

## Typical Properties

Product	Part Number	Active Area ft2 (m2)	Feed Spacer Thickness (mil)	Permeate Flow Rate gpd (m3/d)	Stabilized Salt Rejection (%)	Minimum Salt Rejection (%)
RO-4040-FF element	84286	90 (8.4)	27	2,650 (10)	99.5	98.0
RO-390-FF element	116314 / 100608	390 (36)	27	13,700 (51.8)	99.5	98.0

1. Permeate flow and salt rejection based on the following test conditions: 2,000 ppm NaCl, 225 psi (15.5 bar), 77°F (25°C), pH 8, and 15% recovery.
2. RO-390-FF element Flow rates for individual elements may vary but will be no more than 15% below the value shown, RO-4040-FF Flow rates for individual elements may vary but will be no more than 20% below the value shown.
3. Stabilized salt rejection is generally achieved within 24-48 hours of continuous use; depending upon feedwater characteristics and operating conditions.
4. Sales specifications may vary as design revisions take place.

## Element Dimensions

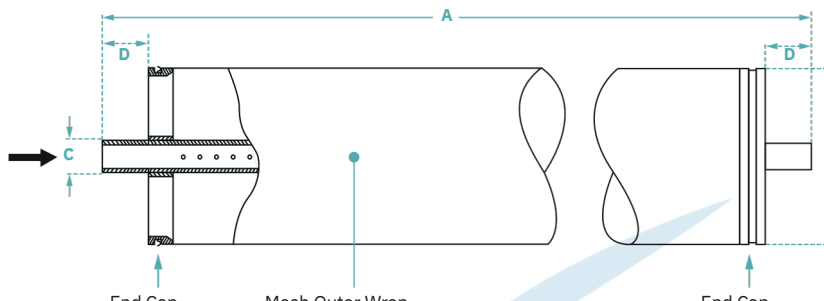

End Cap      Mesh Outer Wrap      End Cap

For model RO-4040, DuPont supplies two end caps (part number 102109), coupler (part number 89048) is ordered separately for each element. Each coupler includes two 2-210 EPR O-rings (part number 89255).

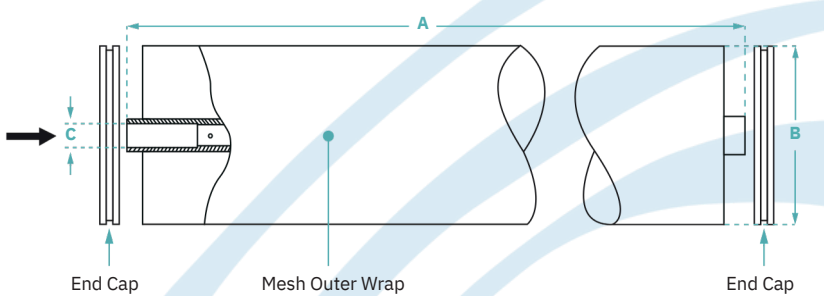

End Cap      Mesh Outer Wrap      End Cap

For model RO-390 supplies two end caps (part number 113199) and one coupler (part number 255289). Each coupler includes two 3-912 EPR O-rings (part number 151705).

Dimensions – inches (mm)	
RO-4040-FF element	
A	40.0 (1,016) 3.9 (99) 0.75 OD
B	(19) 1.05 (27)
C	
D	
OD= Outer Diameter 1 inch = 25.4 mm	

Dimensions – inches (mm)	
RO-390-FF element	
A	40.0 (1,016) 7.9 (201) 1.125 ID
B	(29) 1.19 (30.2)
C	
D	
ID = Inner Diameter 1 inch = 25.4 mm	

1. Model RO-4040 and model RO-390 are not full sanitary design and should only be used when permeate is the product.
2. For element weight information refer to [What is the weight of The company elements as delivered?](#) (Form No. 45-D04811-en)
3. For element packaging and shipping information refer to [How are The company elements packaged and shipped?](#) (Form No. 45-D04811-en)

## Suggested Operating and Cleaning Conditions



Membrane Type	Polyamide Thin-Film Composite
Maximum Operating Temperature <sup>1</sup>	113°F (45°C)
Maximum Operating Pressure	600 psi (41 bar)
Maximum Pressure Drop	
Per Element	15 psi (1.0 bar)
Per Pressure Vessel (Minimum 4 Elements)	50 psi (3.5 bar)
pH Range	
Continuous Operation <sup>1</sup>	3 – 10
Short-Term Cleaning (30 min.) <sup>2</sup>	1 – 12
Maximum Feed Flow <sup>3</sup>	110 gpm (25 m <sup>3</sup> /h)
Maximum Feed Silt Density Index (SDI)	SDI 5
Free Chlorine Tolerance <sup>4</sup>	< 0.1 ppm

1. Maximum temperature for continuous operation above pH 10 is 95°F (35°C).
2. Refer to The Company [Cleaning Guidelines](#) (Form No. 45-D01696-en).
3. For recommended feed and permeate flow rates, flux and recovery for various feed sources, refer to The Company [Design Guidelines for multiple-element systems of midsize elements](#) (Form No. 45-D01588-en).
4. Oxidation damage is not covered under warranty, The Company recommends removing residual free chlorine by pretreatment prior to membrane exposure. Please refer to [Dechlorinating Feedwater](#) (Form No. 45-D01569-en) for more information.

## Important General Information

- Keep elements moist at all times after initial wetting.
- For successful operation of Reverse Osmosis (RO) and Nanofiltration (NF) membrane systems, the operation must follow the guidelines provided in the [The Company Reverse Osmosis / Nanofiltration Elements Operation Excellence and Limiting Conditions Tech Fact](#) (Form No. 45-D04388-en).
- To prevent biological growth during prolonged system shutdowns, it is recommended that membrane elements be immersed in a preservative solution.
- The customer is fully responsible for the effects of incompatible chemicals and lubricants on elements.
- Avoid static permeate-side backpressure at all times.
- Permeate obtained from the first hour of operation should be discarded.
- The use of this product in and of itself does not necessarily guarantee the removal of cysts and pathogens from water. Effective cyst and pathogen reduction is dependent on the complete system design and on the operation and maintenance of the system.

Please consider good operating practices for the optimal performance of the Reverse Osmosis membrane elements to assure damage free operation: 1. [Loading of Pressure Vessels – Preparation & Element Loading](#)

- (Form No. 45-D01602-en)
2. System Operation, including plant [Start-Up Sequence](#) (Form No. 45-D01609-en) and [RO & NF Systems Shutdown](#) (Form No. 45-D01613-en)
3. [Handling, Preservation, and Storage](#) (Form No. 45-D03716-en) Full information of plant design, system operation, and troubleshooting is given in the [The Company Reverse Osmosis Membranes Technical Manual](#) (Form No. 45-D01504-en).

## Regulatory Note

This product may be subject to drinking water application restrictions in some countries; please check the application status before use and sale.

All information set forth herein is for informational purposes only. This information is general information and may differ from that based on actual conditions. Customer is responsible for determining whether products and the information in this document are appropriate for Customer's use and for ensuring that Customer's workplace and disposal practices are in compliance with applicable laws and other government enactments. The product shown in this literature may not be available for sale and/or available in all geographies where The Company is represented. The claims made may not have been approved for use in all countries. Please note that physical properties may vary depending on certain conditions and while operating conditions stated in this document are intended to lengthen product lifespan and/or improve product performance, it will ultimately depend on actual circumstances and is in no event a guarantee of achieving any specific results. The Company assumes no obligation or liability for the information in this document. References to "The Company" or the "Company" mean The Company legal entity selling the products to Customer unless otherwise expressly noted. NO WARRANTIES ARE GIVEN; ALL IMPLIED WARRANTIES OF MERCHANTABILITY OR FITNESS FOR A PARTICULAR PURPOSE ARE EXPRESSLY EXCLUDED. No freedom from infringement of any patent or trademark owned by The Company or others is to be inferred.

Form No. 45-D01733-en, Rev. 4  
March 2025